

# SHAPE-P-036-XR

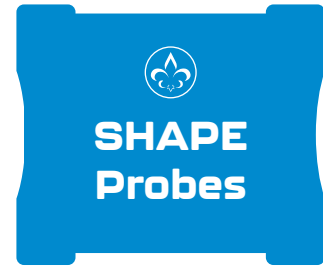

**SG NDT SHAPE probes are an ideal solution** for examining surfaces with varying curvatures and geometries. They can be held in the hand or in a small probe holder, making them a versatile tool for initial testing and proof of concept verification before transitioning to a rigid probe with a fixed geometry.

**The SHAPE-P-036-HR probe** is an extra-high resolution inspection probe with a rubber backing that ensures durability while minimizing the impact on flexibility. These probes have been field-proven as an excellent probe choice for difficult inspections or detecting small defects. The SHAPE probe can be customized to meet specific requirements, making it the ultimate tool for surface Eddy Current Array examination.

## SHAPE-P-036-XR

Technology	PCB Coils
Frequency Range	500KHz – 5MHz
Coil OD	2.35mm
Coil Quantity	2 Rows of 32 Intertwined Coils (total 64)
Probe Coverage	36mm
Topology	Short Single Driver
Channels	31 Axial, 31 Transverses (total 62)
Resolution	1.18mm Axial, 1.18mm Transverse
Curve Radius	20mm
Typical Detectable Defect	> 0.4mm
Cable Length	3m Standard
Maximum Lift-Off	0.5mm

# SHAPE-P-036-XR

## Interchangeability

The flexible array is easily detached from the cable and multiplexer (MUX) assembly and replaced using a single tool. This means that the array can be quickly and easily replaced by other similar arrays with a different coverage, resolution or topology.

Complete P/N :  
**SHAPE - P - 036 - XR**

Flexible shape probe  
Printed coils  
36 mm coverage  
Extra-high resolution probe

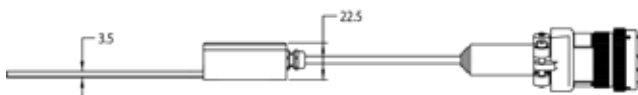
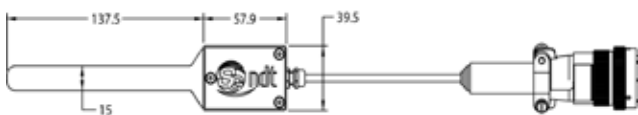
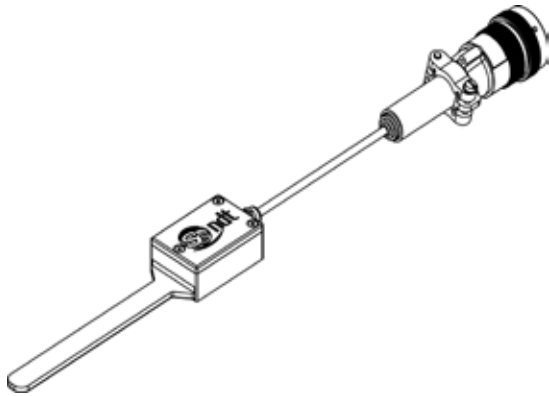

Cable P/N : **CBLS-SHAPE-03M**

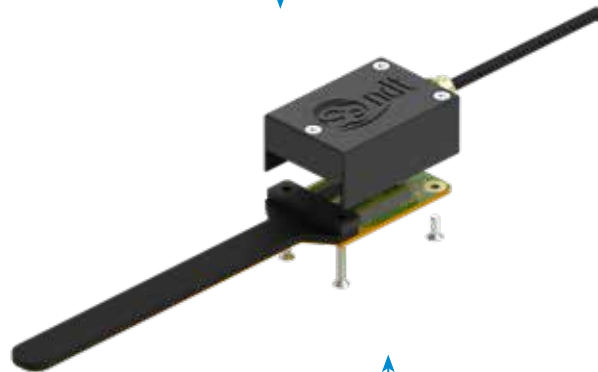

Array P/N : **SFLX-P-036-XR**

**Through innovation,**  
we surpass standard expectations

visit us online at: [sgndt.com](http://sgndt.com)

